



Serial No. 2010-062-01

"ADDS VALUE TO THE LIFE"

User Manual



SCIS
SILVER & COPPER ION STERILIZER

WACO Corp.

www.waco.co.kr

CONTENTS

What is SCIS?

A)PRINCIPLE

B)SILVER & COPPER ION

C)SAFETY

D)ADVANTAGE

COMPOSITION & SPECIFICATION OF SIS

CIRCUIT DIAGRAM OF SCIS

INSTALLATION

OPERATION

MAINTENANCE

CAUTION & NOTE

A)Principle

Generated Silver & Copper ion by Electrolysis- "by flowing DC current to the silver, copper and titanium panels which are attached to STS housing" sterilizes water which gets through this STS housing over the water flow switch.

B)Silver Ion

Natural components of Silver have antibiotic and the sterilizing power and generated ion-colloidal Solution by Electrolysis destroys a single-celled animal-bacteria, virus, various kind of germs by changing proteins of them and ruining their cells however no harmful to multicellular organism or human body as well no toxicity and immunity phenomenon. Small amount of Silver ion can get the greatest effect of sterilization by 99.99% and is quite effective for 640 kinds of bacteria.

Copper Ion

It has a greatest effect on sterilization and extermination for Algae.

C)Safety

WHO regulates recommendation about silver only. In Law Of Safe Water of EPA in USA, any regulations about silver are not made in first type drinking water standard which has the legal binding power. Maximum allowed value regulated in second type drinking water standard which has not any legal binding power is 0.1ppm. This value is a recommended value for health about long or short term safety standard. Also in inspection about carcinogenicity and noxiousness, one which has no evidence or insufficient evidence is classified as D&E group, and is rated as very safe.

By use of Pure Silver(99.99%) & Copper Electrode(99.9%), the generated ~50ppb Silver Ion & ~350ppb Copper Ion are less than the standard of EPA (100ppb of Silver and 1000ppb of copper consistency). SCIS is designed safely much more than TDI (Tolerable Daily Intake) of EPA.

D) Advantage

Chlorine, O-zone and Ultraviolet use for sterilizing swimming pools cause secondary pollution and side effects of hair decolorizing, skin disease, secondary pollution, bad taste and odor. Those conventional sterilization substances couldn't be effective for the sterilization of Virus and Legionella. As those substances are used continuously, it causes the increase of expenses by tolerance of germs.

SCIS is new-safe-cost save effective with high sterilizing power. Specially easy maintenance with lower maintenance coat as an economical sterilizer.

E) Applications

- 1) Cooling Tower
- 2) Swimming Pool
- 3) Sauna, Bath Room
- 4) Spa
- 5) Pond, Fountain System



COMPOSITION & SPECIFICATION OF SCIS

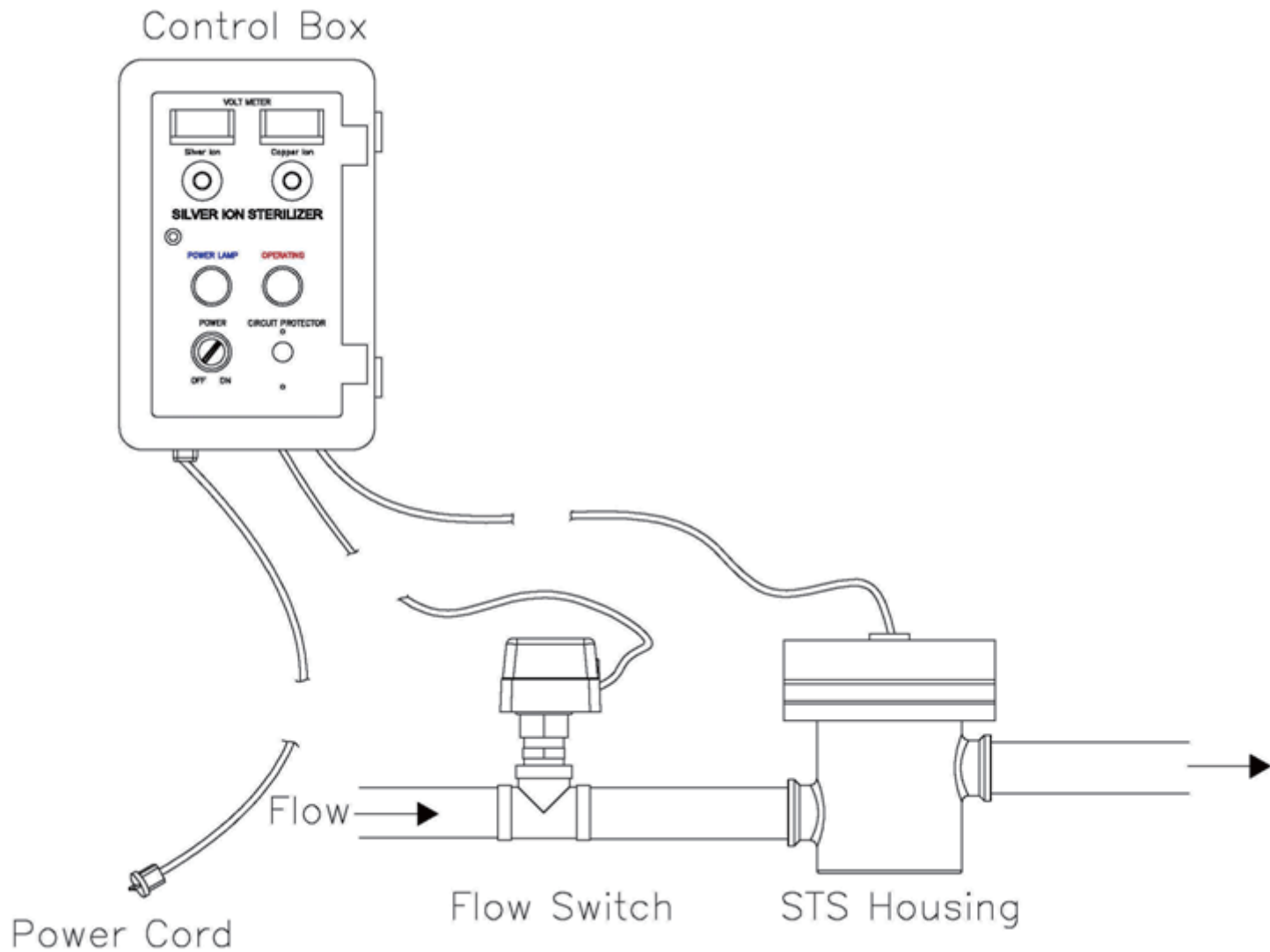

COMPOSITION & SPECIFICATION OF SCIS

	SPEC	
Control Box	Main power	Free voltage : AC 100~240V (50/60Hz)
	SMPS(2.2A)	Input : AC 100~240V, Out put : DC24V
	Constant current controller	Input : DC24V, Out Put : 200mA & 1000mA
	Panel Meter(Volt)	In put : DC24V
	Voltage control lever	
	On-OFF switch	6A 250V
	Main power Lamp	6V (LED)
	Operating Lamp	24V (LED)
Housing	BODY	STS 304 + MC NYLON
	Electrode(pole)	Silver Panel(99.99%) : 1.5T X 1EA
		Copper Panel(99.97%) : 1.5T X 3EA
Titanium panel : 1.5T X 5EA		
Flow Switch	Micro Switch Type	Flow sensor

COMPOSITION & SPECIFICATION OF SCIS

Operation method	Constant voltage & Constant current
In & Out pipe size	15A~40A
Silver & Copper Ion concentration	Silver Ion : ~50ppb (in case of 1.5V setting) - Recommendatory value Copper Ion : ~350ppb (In case of 8.5V setting) - Recommendatory value
	The water condition of a swimming pool (water temperature, electrolysis / etc) shall be checked and tested in advance to get the right value of Silver Ion conc.
Durability	9,000hours (considering the operation of 8 hours per a day, about 3~4 years available)
* Depends on the condition of water, durability and generation of Silver Ion will be different.	

* Size & Weight

	SIZE(W X L X H / mm)	Weight(kg)
Control box	225 X 150 X 310	2.5
STS Housing	160 x 195	4.5
Flow Switch	65 x 80 x 155	1.5
Packing	400 x 300 x 400	12

CIRCUIT DIAGRAM

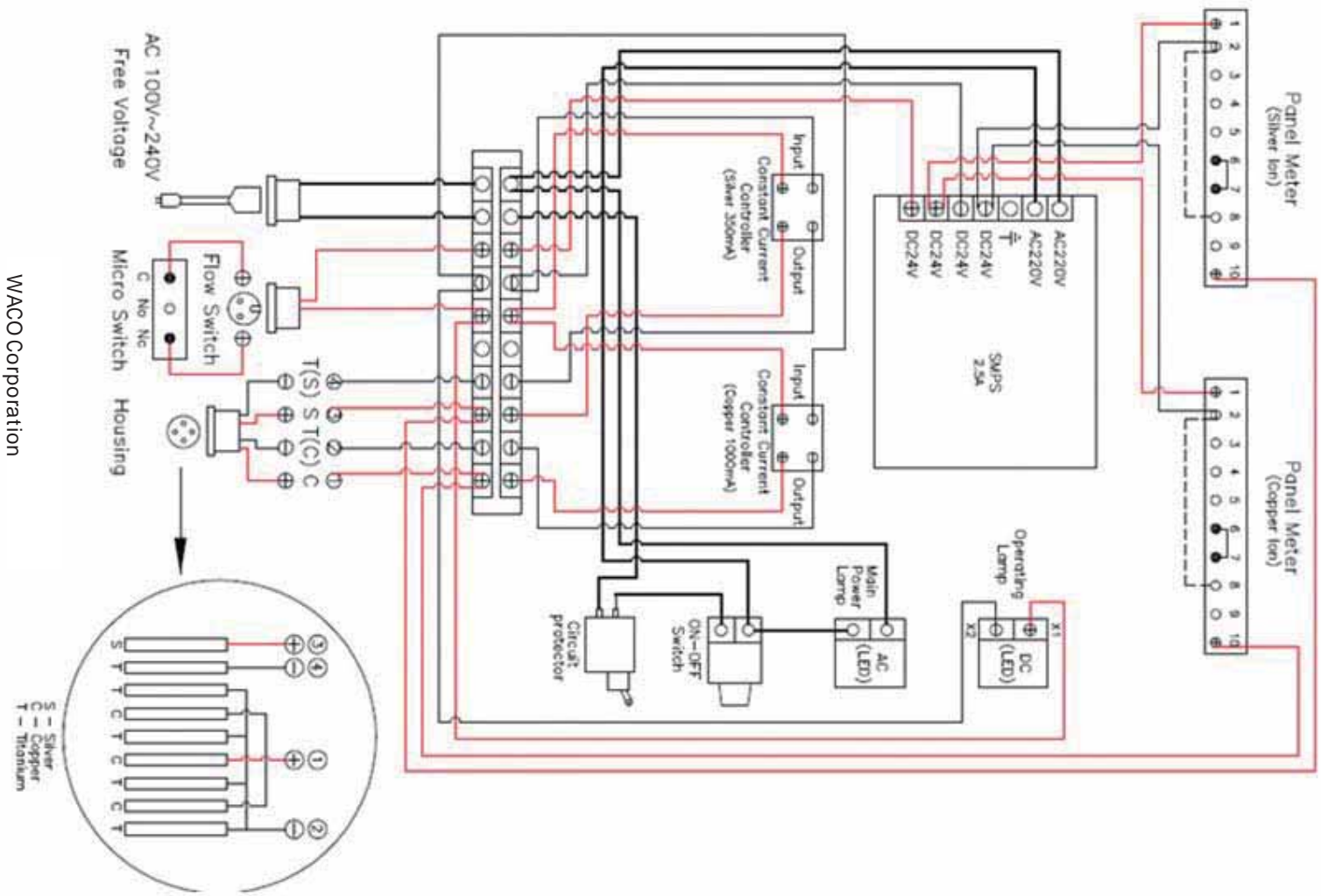

WACO Corporation

INSTALLATION

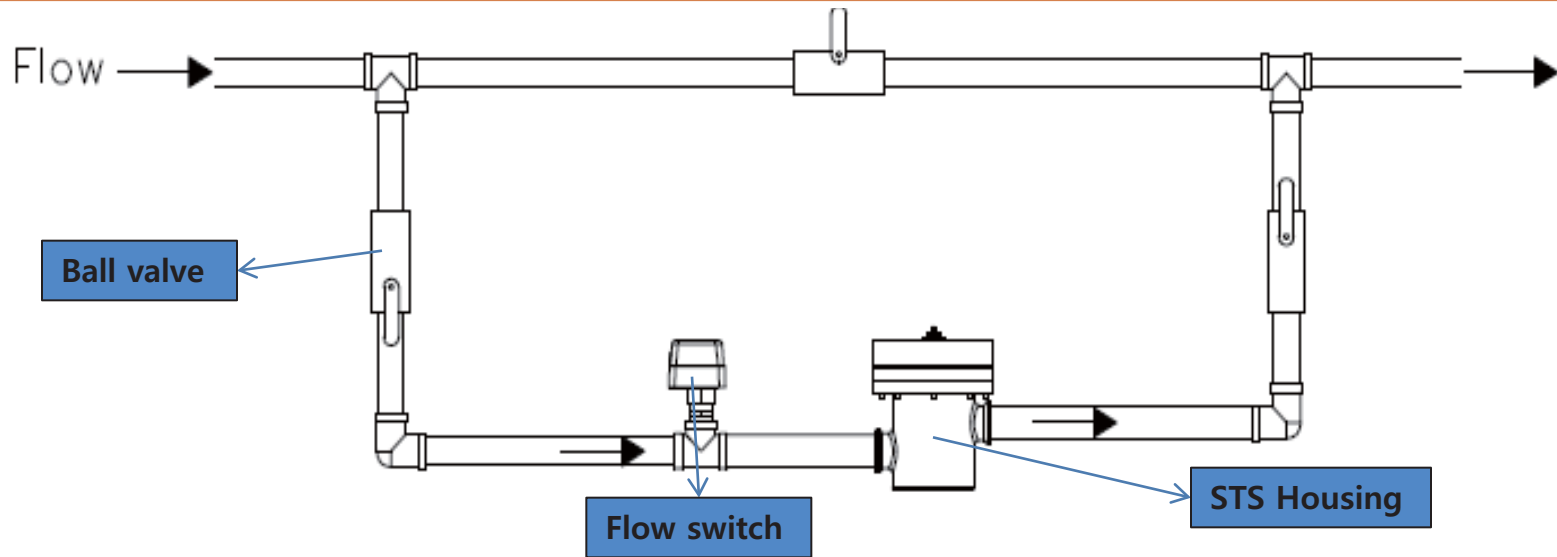

By using "BY PASS" PIPE as the above drawing, connect our STS Housing ,FLOW SWITCH, and each "ball valve"

※ CAUTIONS

1. Flow Switch and STS Housing have to be installed in front of a water pump(not after pump) to prevent any possible damage of them(Flow Switch and STS Housing) by high pressure impacts caused by Water Hammer.
2. Pressure Reducing valve shall be installed before Flow Switch to be able to protect Flow Switch and STS Housing against any possible damage under high water pressure circumstance and by Water Hammer matter.
3. Inlet water working pressure for Flow Switch and STS housing should be under 8bar and Max. 10bar.

OPERATION

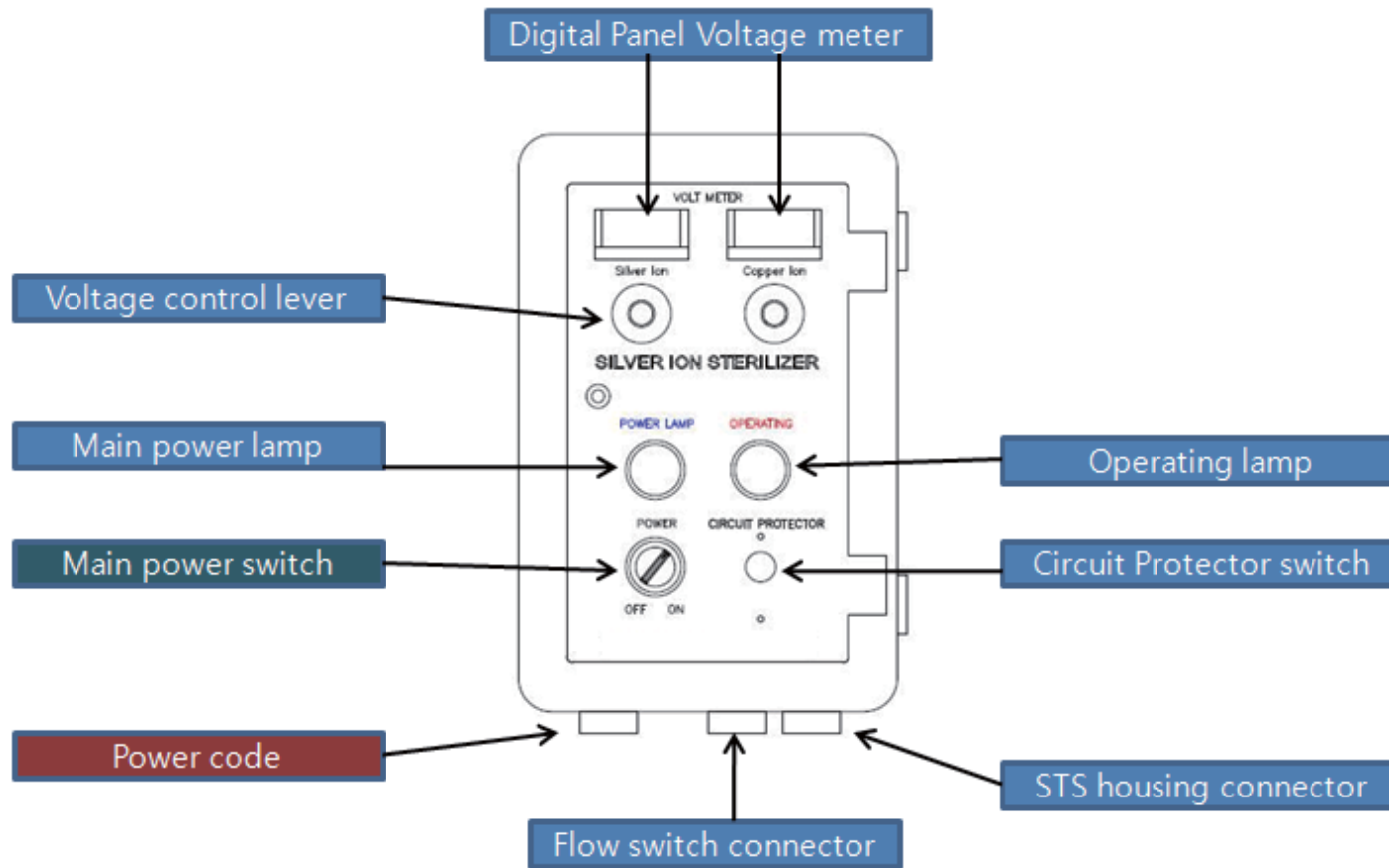

※ CAUTIONS

Control box functions to control minute electric currents thus NEVER allowed to be connected to other electric devices carelessly coz it will cause malfunction of the control box by electric shock.

OPERATION

1. After installation of SCIS and Flow switch through BY PASS, they(SCIS and Flow switch) shall be connected to the Control Box as the above drawing,
2. Then, power plug shall be connected to the Control box as the drawing,
3. Turn on the Main power switch then Main power lamp is on
4. Open the ball valve, the sensor of the flow switch let an electric current flow to the each pole then, silver & copper ion are generated(at this moment, Operating lamp can be on)
5. The Digital Panel meter and if necessary, control the voltage value by the Voltage controller.
(Silver Ion : 1.5V / Copper Ion : 8.5V)
6. After finishing operation, the flow switch senses no water flow and cuts off electric current to stop emitting of silver & copper ion(Operation lamp can be off)
7. As it's not used for a long time, turn off the main switch and plug out of the outlet

Disassemble flow cell very 3 months and clean or remove any scale from the each pole for smooth operation and long life.

The replacement and Cleaning

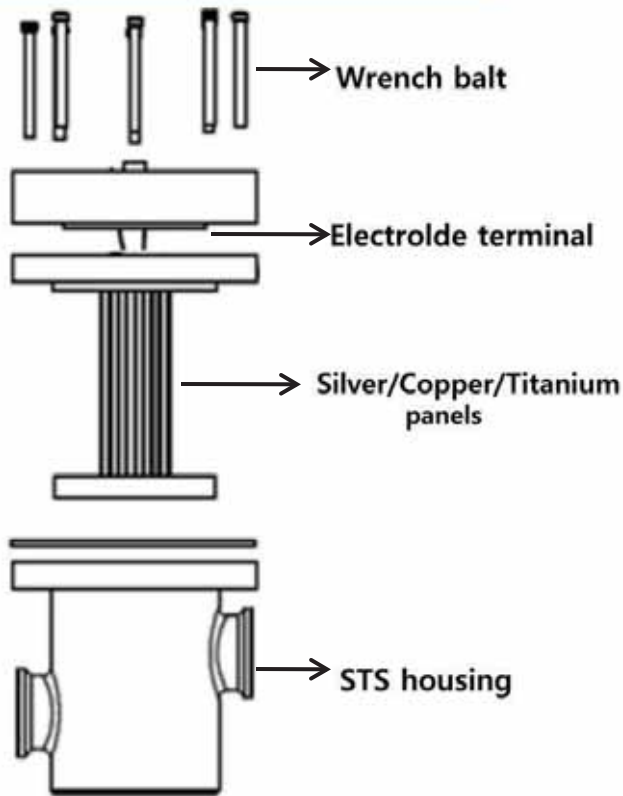

- 1) Turn off the power switch and disconnect the power plug
- 2) Disconnect STS housing from the control box
- 3) Undo the 5 wrench bolts which hold the cover
- 4) Lift the top cover assembly from the STS body for the separation
- 5) Silver panels, Copper panels and Titanium panels shall be cleaned with soft brush and remove any scale from panels
(be careful not to let any water flow to the electrode terminal of inside top cover)
- 6) Assemble them again after cleaning



Management in case of malfunction

Cause	Management
In case of Power shutting off	Check whether Power cord is connected with Wall out or Control Box.
	Check whether Circuit switch is off.
In case of non operating even turning on main power	Check whether Flow switch of Control box is connected with STS housing of Control box.
	Check whether the speed of a running fluid is smooth (Perceivable Flow switch : 3 bar)
	Open Upper cover of Flow Switch and check Micro-Switch
In case of non - lighting of LED	Change the standardized and correct LED LAMP
In case of the connection part leakage of STS housing cover	Assemble after checking whether Gasket is destroyed by disassembly & assembly

- Connect after checking IN/OUT directions once connecting pipes with Flow Switch & STS housing
- Assemble after checking Marked parts that has Assembly directions once assembling or disassembling STS housing & Electrode (Pay attention that water does not flow into the connection part once assembly or disassembly)
- Connect DC or Electrode part to the correct connection part because they have their own polarized positive or negative electrode.

CAUTIONS

Following cautions about safety are to prevent unexpected harms beforehand. Please use this facility carefully according to this guide.

- Surely pay attention in Electric Shock wherever Electricity can flow
- Use the standardized & correct parts once need to replace parts
- Un-plug once need to reinforce, assemble, disassemble or replace parts
- Recover the primary wiring to avoid Electric Shock, troubles, and fire after repair or reinforcement

NOTE

- Implement after being familiar with Manual before installation, operation, maintenance or reinforcement
- Do not assemble or remodel products excepting engineer
- Pay attention not to damage or to fall drop products once movement or installation
- Check whether Electric Power and Piping are connected correctly before operation
- Check all sections where leakage can occur at all times
- Clean hands after maintenance or reinforcement